



CCT Lighting

Swift Floodlight



Description:

Elevate your architectural lighting with the Swift Floodlight, a premium exterior fixture designed to illuminate large-scale structures precisely and efficiently. Dual adjustable heads enable fine tuning of beam angles on-site without the need for costly spread-lenses.



Output:

Lumens all channels on: 24,000

Lumens per Channel:

R 4,100 / G 8,660 / B 2,400 / W 12,420

Efficacy: 70 lm/w

Head Beam Angle: 15°

Full Unit Adjustable Beam Angles:

15°, 25°, 40°, 50°

CRI: 80

Lumen Maintenance: L70: ≥55,000 hours

Electrical:

Power Consumption: 380 W

Rated Voltage: 120-277 VAC

Rated Frequency: 50/60 Hz

Control:

Interface: DMX 512

Pending Certifications:



Physical:

LED Manufacturer: Cree

Housing Material: Aluminum

Lens Material: Tempered glass

Vibration Rating: 5G, 3G with slipfitter mount (ANSI C136.31)

Ambient Temp Rating: -20°C to 50°C

Weight: 21.8kg

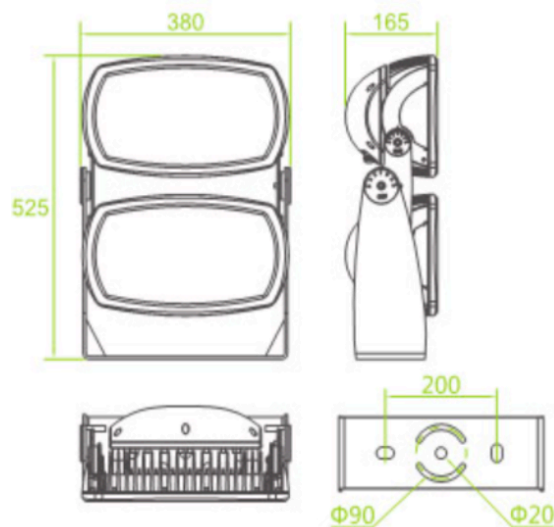

Warranty: 5 Years (labor not included)